

Product Set-Up & Installation for Ground Slabs

PLUMBER

Slab is boxed out to expose piping. Pipes can be roughed into corner of boxing (Remove Boxing)

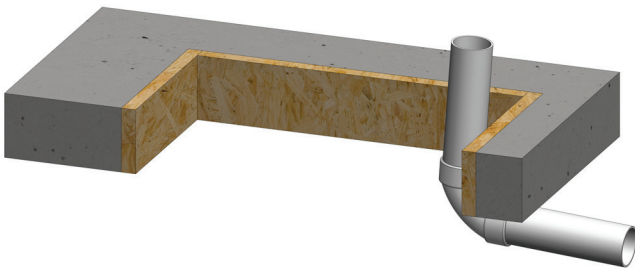

Elbows & piping are used to establish waste location

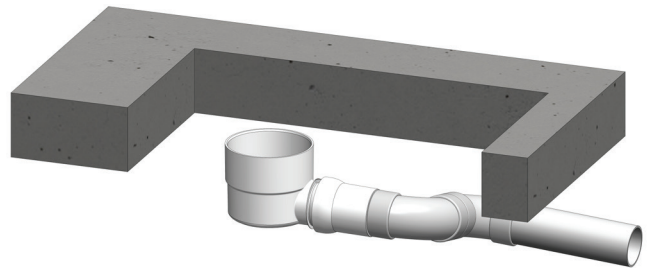

TILER

Install DWV100 extension & back-fill cavity, checking levels

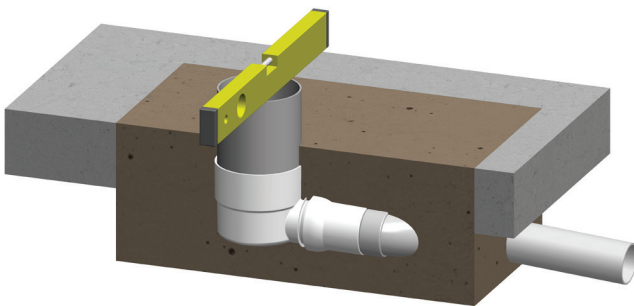

Trim DWV100 extension to desired height

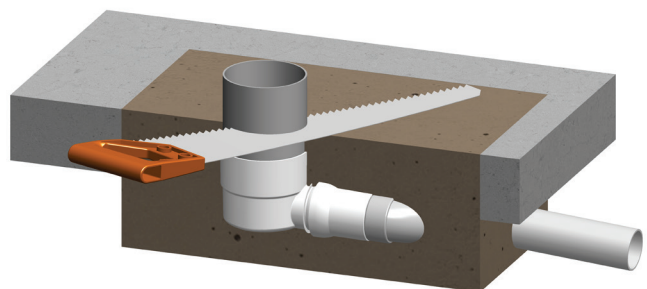

Product Set-Up & Installation for Ground Slabs

Apply adhesive to Floor

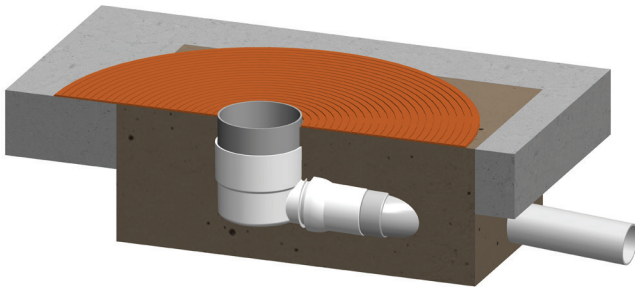

Install the Pre-Formed Taper Board

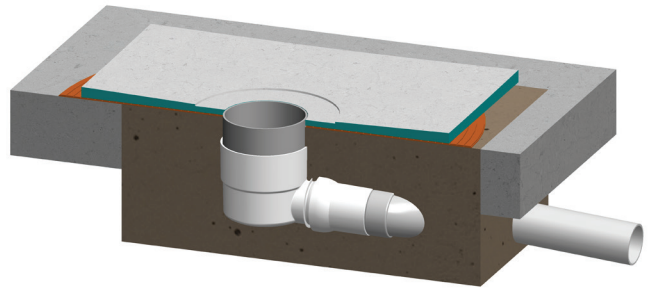

Install Liquid Membrane Flange into DWV100 and seal to Pre-Formed Taper Board

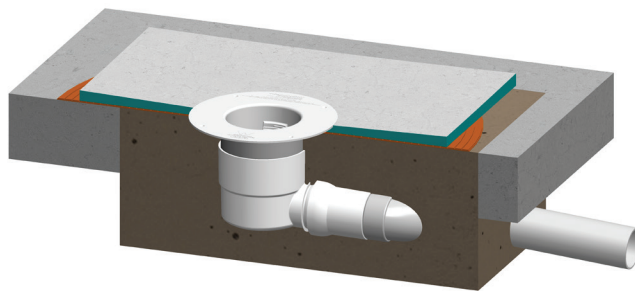

Approved Waterproof Membrane must be detailed down into the throat of Liquid Membrane Flange to the top of Threads

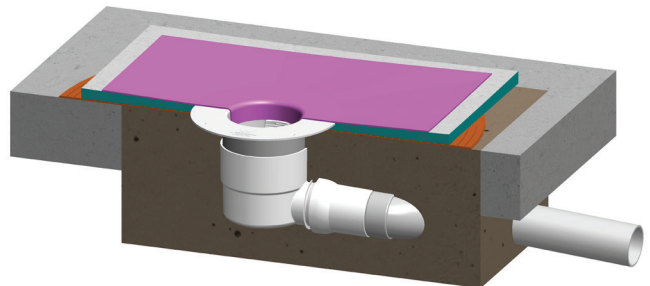

Screw down the Tiling Flange Assembly to finished Tile Height -1mm

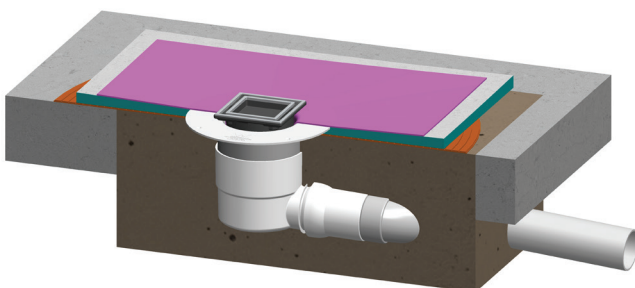

Tile & Grout to standard practice

