

Specifications



Stainless Lid 1000.171



Tile Insert 1000.172

Flow rate 80-140 l/min
 Water seal None
 Inlet size 100mm
 Outlet size 50mm

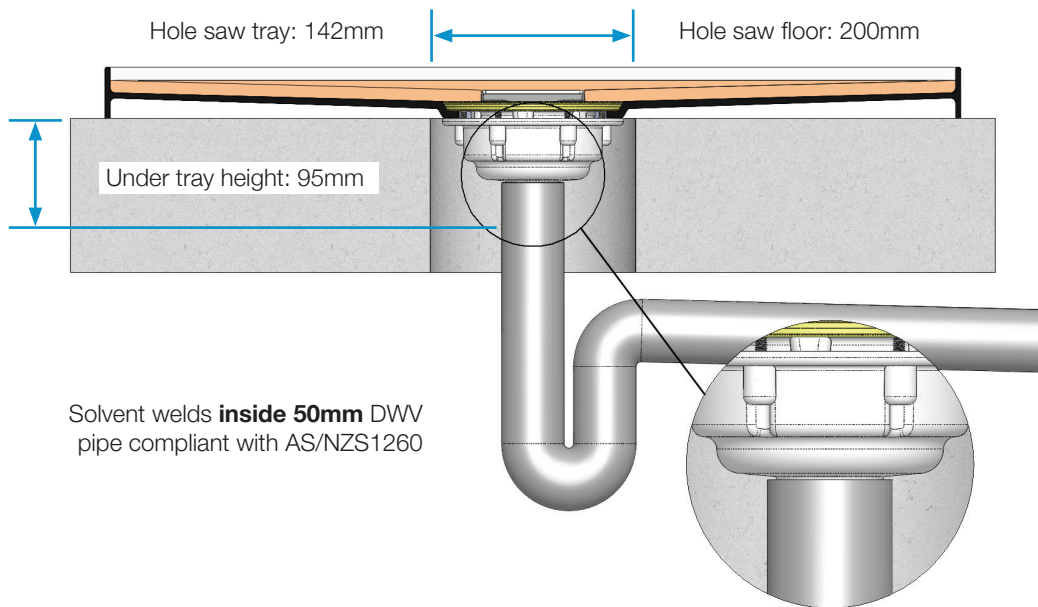

Spare Parts Ordering Codes

All spare parts are NON-RETURNABLE, please ensure that correct part has been ordered
 Turn to page 23

Stainless Lid TT SL HF BE50i 1000.171
 Tile Insert TT TI HF BE50i..... 1000.172

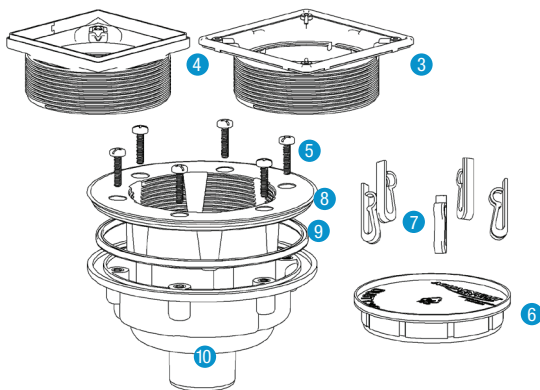

1.Lid Assembly SL HF 1001.251
 2.Lid Assembly TI HF 1001.261
 3.SL Tiling Flange Assembly 1001.231
 4.TI Tiling Flange Assembly 1001.232
 5.TT Clamp Ring Screw Kit 1001.711
 6.TT Dust Cap 1001.401
 7.Glue Clips 1001.699
 8.TT Clamp Ring 1001.621
 9.TT Lower Seal 1001.601
 10.TT HF BE50i Body 1001.161